

# Compact Locomotive Radio Control System

Hubbell Radio Remote Control Systems

Spec Sheet 31.210 • August 2000 • New

## Internal Diagnostics

- Run by microprocessor on internal programs
- Run by microprocessor on commands and I/O
- Power-up diagnostics
- Continuous monitoring

## Operational Status Readout

- English language display of status

## Controls System Features

- New "Compact" receiver with diagnostic display module
- New "Compact pneumatics interface with analog valves for throttle/brake
- For use with any of the Hubbell transmitters, see Catalog 31.300

## Compact Receiver

- Proven rf module and micro I/O module from radio crane control
- New "E-Stop" board
- New plug-in output interface cards
- Frequency: 72-76 or 450-470 MHz FM
- NEMA 12 enclosure - 24" h x 24" w x 12" d

## Compact Pneumatic Interface

- Very compact manifold/valve assembly
- Analog valves for throttle and train-line brake control
- Analog pressure indicators
- NEMA 12 enclosure - 24" h x 24" w x 12" d

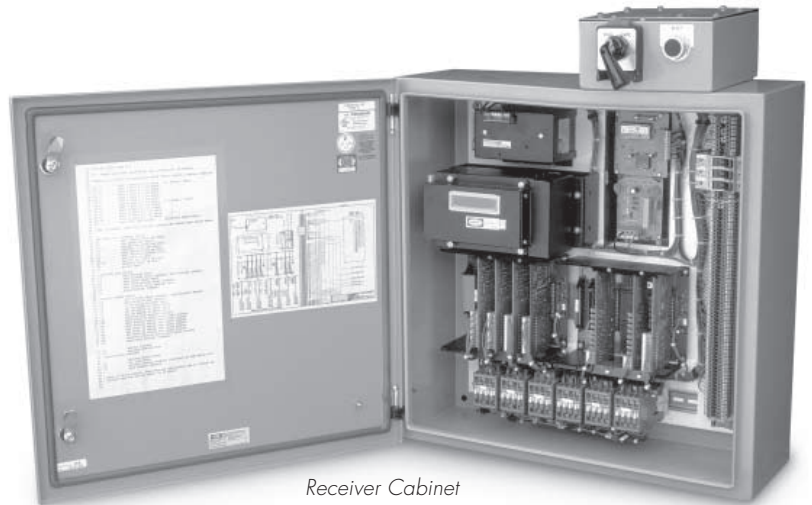

Receiver Cabinet

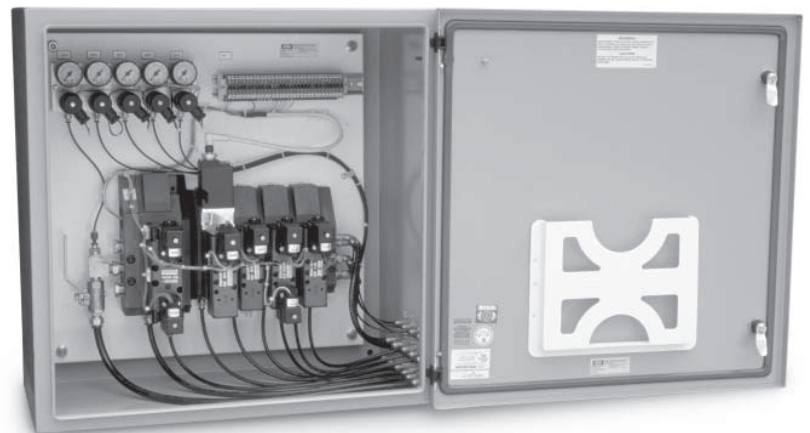

Pneumatics Cabinet

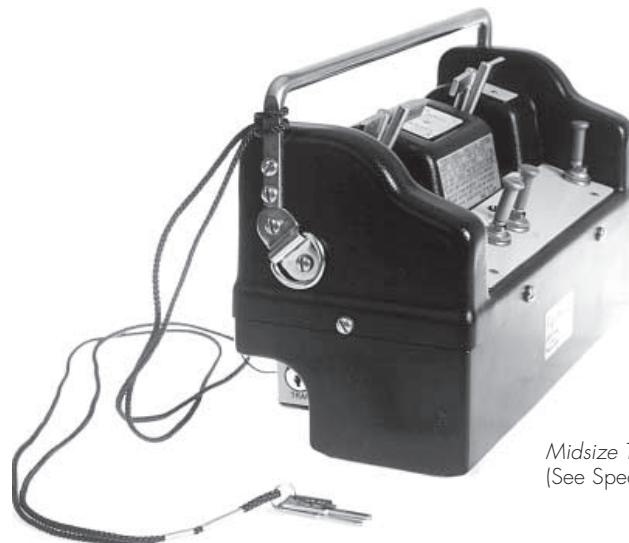

Midsize Transmitter  
(See Spec 31.320)

## Outline Drawings

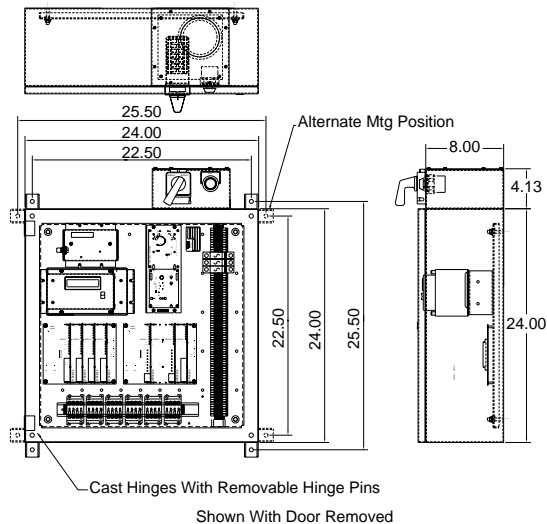

Receiver Cabinet  
Weight — 90 lbs.

Pneumatic Cabinet  
Weight — 110 lbs.

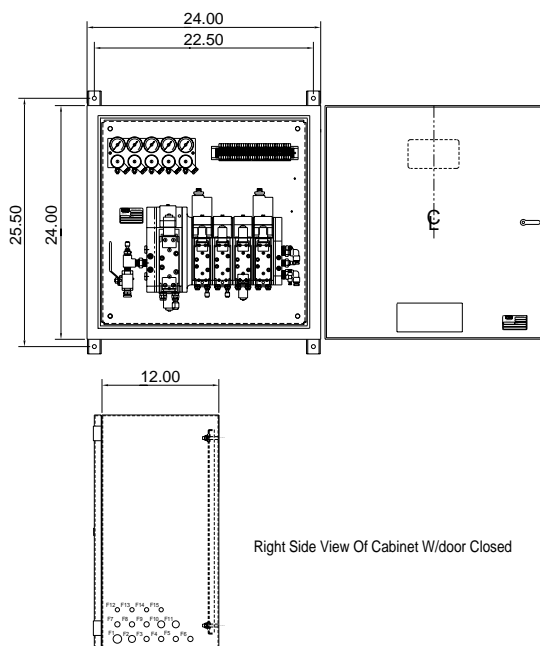

Right Side View Of Cabinet W/door Closed



**Hubbell Industrial  
Controls, Inc.**

*a subsidiary of  
Hubbell Incorporated*

50 Edwards Street  
Madison, Ohio 44057  
(440) 428-1161  
Fax (440) 428-7635

4301 Cheyenne Drive  
Archdale, NC 27263  
(336) 434-2800  
Fax (336) 434-2801

## Specifications

Supply Voltage ..... 12VDC, 24VDC, 36VDC or 72VDC  
Internal Power Requirements ..... +11.9–13.1VDC & +4.5–6.5VDC, 24 VDC  
Operating Temperature ..... -22°F (-30°C) to 140°F (+60°C)

### Radio Receiver

Frequency Range ..... 72–76 MHz or 450–470 MHz  
Channel Availability ..... as required by user  
Frequency Stability ..... ±5 ppm  
Sensitivity ..... 1  $\mu$ v @ 20 dB quieting  
Data Reception ..... compatible with Hubbell transmitters  
Modulation ..... Manchester II (bi-phase)  
Baud Rate ..... 4800 bps  
Message Format ..... preamble, sync, start flag, address, control, CRC check code

### Control Section

Single board computer consisting of 80C31 controller, 64k EPROM, EPLD containing circuits for bi-phase decoding

### DC Output Section (Electro-mechanical relays)

Panel mounted mother-board to accommodate 4 plug-in relay boards, each with 6 output relays, for a maximum of 24 ac output relays and 12 sense inputs

Indicators ..... LED on each output  
Feedback Sensing ..... opto-isolated input from: AIR PRESSURE, THROTTLE, BRAKE, FORWARD, REVERSE relay outputs  
Relays ..... Standard PC board relays  
Output Rating ..... 115/230V ac, 50/60 Hz, 5A resistive;  
12/24V dc, 5A resistive  
Isolation ..... 5000V

### DC Output Section (Stepped analog outputs)

Panel mounted mother-board to accommodate 4 plug-in boards, each with 1 analog output.

Indicators ..... LED on each of 8 levels  
Output Rating ..... 0–10V dc, 20mA, in 8 steps  
Isolation ..... 5000V

### “E-Stop” Board

Plug-in PC board (plugs into motherboard of DC Output Section in place of 1 electro-mechanical relay board)

Indicators ..... LED on each of 5 inputs and 1 output  
Inputs ..... 5 inputs, optically isolated  
Isolation ..... 5000V

### Control Relays (DIN Rail Mounted)

Individual control relays, as required for locomotive functions.

NEMA P300 DC Inductive Rating ..... 5A Continuous at 250VDC Max.  
138VA Make & Break Max.